

Relating Hippocampal Circuitry to Function: Recall of Memory Sequences by Reciprocal Dentate–CA3 Interactions

Viewpoint

John E. Lisman

Department of Biology

Volen Center for Complex Systems

Brandeis University

Waltham, Massachusetts 02454

The hippocampus is composed of several regions, each of which is a network of 10^5 to 10^6 neurons. The pattern of excitatory synaptic connections within and between regions has been determined, and the “wiring diagram” is shown in Figure 1. The intricacies are striking and beg for explanation, but it remains unclear how the connections work together to perform a function. Indeed, more generally, the goal of relating network connectivity to function has not been achieved for any region of the vertebrate central nervous system, with the exception of the retina. For many brain regions, the goal is a distant one, because not even the function of the region is known. For the hippocampus, the goal appears attainable, because the general function of the hippocampus in memory processes is established. Many models that relate aspects of hippocampal circuitry to memory function have been proposed, and these have become more refined as new information has been learned about the cellular, network, and functional properties of the hippocampus (Jarrard, 1993; O’Keefe and Recce, 1993; Buzsáki and Chrobak, 1995; Muller, 1996; Eichenbaum, 1997; Nadel and Moscovitch, 1997; Squire and Zola, 1998; Tulving and Markowitsch, 1998). In this paper, I propose a model that builds on several previous ones and is the first attempt to provide a coherent explanation of all of the connections shown in Figure 1.

The early view of the hippocampus was that information flowed serially through its regions and that the CA3 region was the most critical for memory storage. As shown in Figure 1, axons from the entorhinal cortex excite the granule cells of the first hippocampal region, the dentate gyrus; the granule cells then excite the pyramidal cells of the CA3 region, which then excite the pyramidal cells of the CA1 region (Figure 1). CA1 cells provide an output of the hippocampus back to the cortex. First generation models of the hippocampus (Marr, 1971; McNaughton and Morris, 1987; Treves and Rolls, 1992) proposed that memories were stored in the CA3 region and that the storage was “autoassociative.” The term autoassociative means that synaptic links are strengthened between cells that represent different components of the same memory. These links allow a complete memory to be recalled when only a few components are presented. The proposal that CA3 is an autoassociative memory network was based on three observations. First, the axons of CA3 pyramidal cells make excitatory synapses with numerous other pyramidal cells of the CA3 region, thus forming a “recurrent” network. Second, these synapses undergo an activity-dependent modification of synaptic strength termed long-term potentiation (LTP). Third, the particular kind of LTP found at these synapses has a “Hebbian” property

whereby a synapse is strengthened if there is both pre-synaptic and strong postsynaptic activity. According to neural network theory (Kohonen, 1978; Hopfield, 1982), networks having these properties are capable of storing large numbers of autoassociative memories in their recurrent synapses.

Over time, it has become clear that the flow of information through the hippocampus is not strictly serial and that the CA3 network is not the only recurrent network. Specifically, it was found that CA3 and CA1 pyramidal cells cannot only be excited by the preceding network but also by direct inputs from the entorhinal cortex (Figure 1). It was also discovered that the dentate region is a recurrent network, although a more complicated one than CA3 (Buckmaster and Schwartzkroin, 1994). Dentate granule cells excite mossy cells, another type of cell in the dentate gyrus (Scharfman et al., 1990). These cells make modifiable excitatory connections back onto granule cells (Hetherington et al., 1994; Jackson and Scharfman, 1996), thus forming a recurrent network. The final major finding was that the pyramidal cells of CA3 have axon branches that produce excitatory feedback to the dentate network (Ishizuka et al., 1990; Penttonen et al., 1997). Thus, the hippocampus has two recurrent networks, and these are reciprocally connected (Figure 1). There has been no previous proposal for the function of this reciprocal connectivity.

Evidence for the Storage and Recall of Memory Sequences in the Hippocampus

In trying to relate hippocampal circuitry to memory function, it is important to understand that there are several different kinds of memory and that the hippocampus stores only “episodic memories,” memories that can be formed during a single occurrence, can be articulated (in humans), and that are linked to the particular context in which the event(s) occurred (Dore et al., 1998; Tulving and Markowitsch, 1998). The hippocampus appears to be a long lasting and perhaps permanent repository of a high-level representation of these memories (reviewed by Nadel and Moscovitch, 1997). Through feedback connections to the cortex, hippocampal neurons can activate a more detailed, lower-level representation that is stored in the cortex. Evidence that will be summarized in the following paragraphs indicates that the hippocampus may be especially important in the episodic memory of sequences. An example of such a memory would be: at the zoo (context), Jerry dropped his candy (memory 1), the monkey in the cage grabbed it (memory 2), and Jerry was sad (memory 3).

One line of evidence for the storage of sequences in the hippocampus comes from the effect of hippocampal lesions on sequence learning in the rat (Honey et al., 1998). Normal rats can learn multiple two item sequences and orient to items that are out of their normal sequence. Rats with hippocampal lesions orient to altogether novel stimuli but do not orient when only the sequence of familiar items is changed. Other tests of sequence learning also reveal impairments in animals

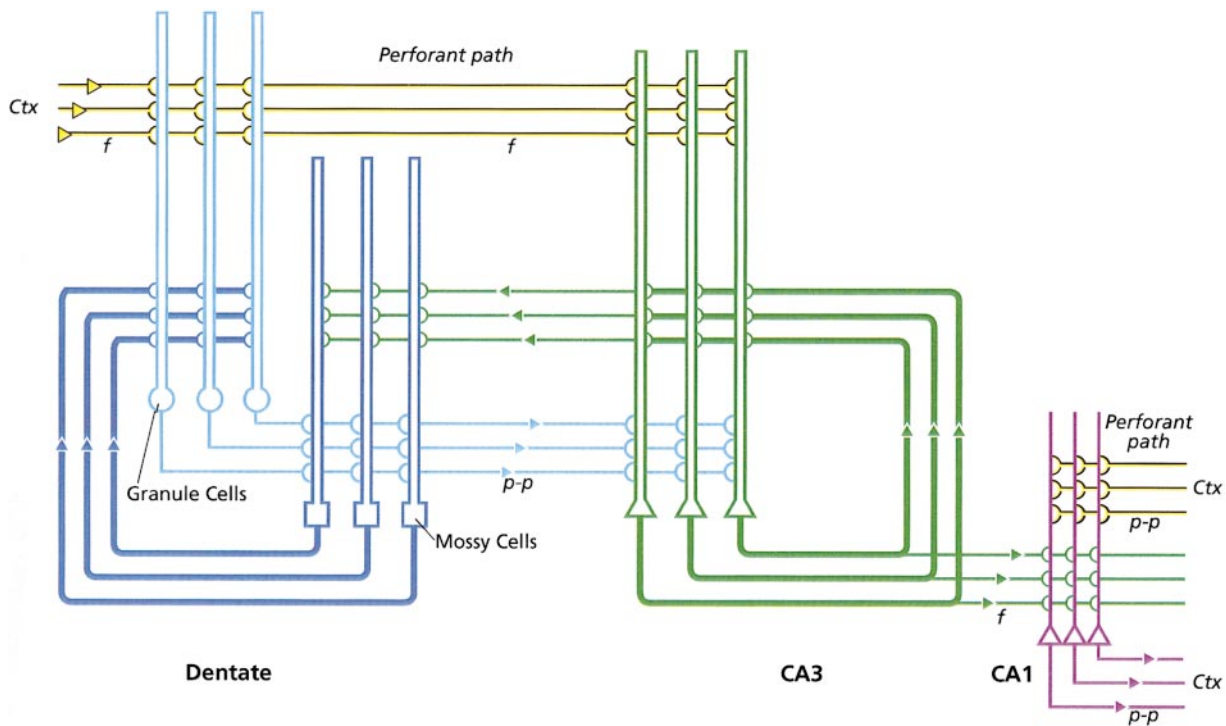

Figure 1. Wiring Diagram of the Excitatory Pathways of the Hippocampal Region

The dentate and CA3 are two reciprocally connected recurrent networks. CA1 receives input from CA3 and the entorhinal cortex and provides an output back to the cortex (for details, see Johnston and Amaral, 1998). Abbreviations: Ctx, entorhinal cortex; f, fanning; and p-p, point-to-point (see Buzsáki, 1996). For simplicity, pathways are shown connecting to each target cell, but in actuality, only a fraction of these connections occurs. The input from Ctx to the dentate and CA3 is called the perforant path. The perforant path to the dentate and CA3 comes from layer 2, whereas the input to CA1 comes from layer 3. Minor connections not shown are input onto granule cells (Wolfert and Lipp, 1995) and CA3 cells. Mossy cells also receive excitatory input from the perforant path (Scharfman, 1991).

with hippocampal lesions (W. E. DeCoteau and R. P. Kesner, 1998, *Soc. Neurosci.*, abstract; Wallenstein et al., 1998).

A second line of evidence indicating the importance of sequences comes from the study of hippocampal place cells. These cells fire when the animal is in a particular location in the environment. Different place cells have different place fields and collectively map the environment (O'Keefe and Dostrovsky, 1971). During sleep, there is a tendency of place cells to fire in the same sequence as they fired during the movement of the rat in the earlier awake state (Skaggs and McNaughton, 1996; Qin et al., 1997). It is thought that this sequence replay may be important for memory consolidation.

Finally, recordings from hippocampal place cells show a firing pattern termed the "phase-advance" that has been interpreted as a prediction of sequential upcoming positions along a well known path. This pattern occurs as the rat moves and while its hippocampus is generating a network oscillation at theta frequency (4–10 Hz). The key observation is that as the rat moves through a cell's place field, the cell fires with progressively earlier phase (Figure 2a) on successive theta cycles (O'Keefe and Recce, 1993; Skaggs et al., 1996). A simple interpretation of this phase-advance (see Figures 2a and 2b) is that it reflects a prediction of the sequence of upcoming places cued by the rat's current position (Jensen and Lisman, 1996a; Tsodyks et al., 1996; but see Kamondi

et al., 1998). The sequence is said to be "time-compressed," because it is played out within a theta cycle at a rate more rapid than the actual traversal of the places. Theta oscillations are subdivided by faster gamma oscillations (40 Hz) (Bragin et al., 1995), and these may organize the readout of sequential locations during a theta cycle, as diagrammed in Figure 2. According to this view, the memory of a particular location (or more generally, an event or object) is encoded by a group of cells that fire synchronously during a particular gamma cycle that has a particular phase within the theta cycle. The hippocampus thus uses what is termed a phase code. A model based on this idea (Figure 2b) leads to the prediction that the average phase-advance should be one gamma cycle per theta cycle, a prediction in reasonable accord with experiments (Jensen and Lisman, 1996c). Having a rapid, time-compressed readout of memory sequences is of obvious utility in preparing the animal for what is to come (the next time Jerry drops his candy at the zoo, he may pick it up more quickly).

The ability of the CA3 recurrent network to synaptically encode sequence information during learning follows straightforwardly from what is known about the biophysical basis of LTP. At the recurrent synapses of CA3, LTP depends on the NMDA class of glutamate-activated receptors (NMDAR). These receptors mediate a Hebbian form of plasticity that is triggered when released glutamate binds to the NMDAR, and

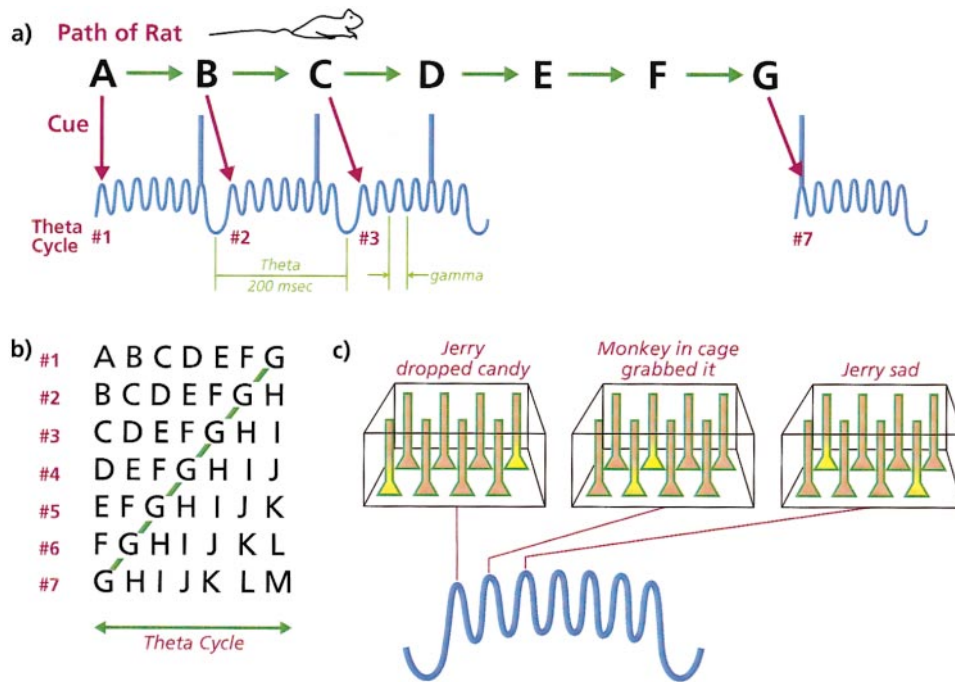

Figure 2. The Phase-Advance of Hippocampal Place Cells May Reflect the Recall of Sequences Organized by Theta (5–10 Hz) and Gamma (~40 Hz) Oscillations

(a) A rat moves through a sequence of positions (A–G), causing the firing of a place cell over this entire region. The firing of the G cell occurs with earlier and earlier phase of theta cycles as the animal moves along this well known path, a phenomenon known as the phase-advance. Successive theta cycles are labeled 1–7. This can be explained (Jensen and Lisman, 1996a) as follows: the G cell represents position G, a region much smaller than the entire place field (A–G), but fires at positions A through F as part of a sequence recall process. This process is initiated at the beginning of each theta cycle by a cue signifying the current position of the animal. The cells encoding this position become active in the first gamma cycle and in turn activate cells encoding the next position in the sequence in the next gamma cycle. This sequence prediction can go on until the last gamma cycle of a theta cycle. As the animal is moving, the cue at each successive theta cycle is further along the path.

(b) Diagram showing how on each theta cycle, the firing of the G cell occurs earlier in the predicted sequence, i.e., at an earlier gamma cycle within a theta cycle.

(c) Illustration of how multiple memory items in a sequence can be active in different gamma cycles (which have different phase relative to a theta cycle). This is what is meant by a phase code. Note that each memory (a place or event) is represented by the subset of cells that fires in the same gamma cycle (yellow indicates firing). Phase coding may occur when the hippocampus is in recall mode (as in [a] and [b]), but also when it is in learning mode. In the latter case, it acts as a “multiplexing buffer,” as follows: a memory item is inserted into the buffer and fires in a given gamma cycle on many successive theta cycles; when the next item is presented, it is also maintained by the buffer, but in a different (later) gamma cycle. The biophysical processes required for a multiplexing buffer are as follows. First, the firing of pyramidal cells activates intrinsic conductances that produce a positive going ramp critical for the reactivation of memories on subsequent theta cycles. Second, rapid feedback inhibition onto pyramidal cells generates 40 Hz oscillations and organizes a winner-take-all process in which only the most excitable cells (encoding the next item in the sequence) fire in a given gamma cycle. Third, a recurrent autoassociational network with weights encoding each item make the cells that encode an item fire as a group, thereby imparting resistance to noise (see simulations of 1–3 in Jensen and Lisman, 1996b, 1996c).

there is substantial postsynaptic depolarization. Because NMDARs in the CA1–CA3 region deactivate slowly (>100 ms) (Debanne et al., 1995), LTP can occur even if postsynaptic depolarization occurs with a 100 ms delay after glutamate release (Gustafsson et al., 1987). This delay window has important implications for sequence learning; if, as the animal moves, place cells A and B are sequentially activated within 100 ms, the synaptic connection from cell A to cell B will be strengthened (Blum and Abbott, 1996), and this would be similarly true for the elements in a longer sequence (A cells become strongly connected to B cells, which are strongly connected to C cells, etc.). It is important to note that the strengthening of connections is asymmetrical (B cells become strongly connected to C cells but not vice versa). Thus, if B cells were to be activated

during a recall process, they would activate C cells, not A cells, thereby reproducing the sequence that was actually experienced.

The mechanism described in the previous paragraph could lead to the encoding of memory sequences in which sequential events have a temporal separation of <100 ms, but what about the more common situation in which the temporal separation is much larger? The encoding of such sequences may depend on a short-term memory buffer that can extend the period of active firing for many seconds. Because hippocampal neurons tend to fire for many seconds after a brief stimulus (Vinoogradova, 1984; Hampson et al., 1993; Colombo and Gross, 1994), the hippocampus must either itself be a buffer or be driven by a network that has buffering ability (Figure 2b). Such persistent firing allows a single brief

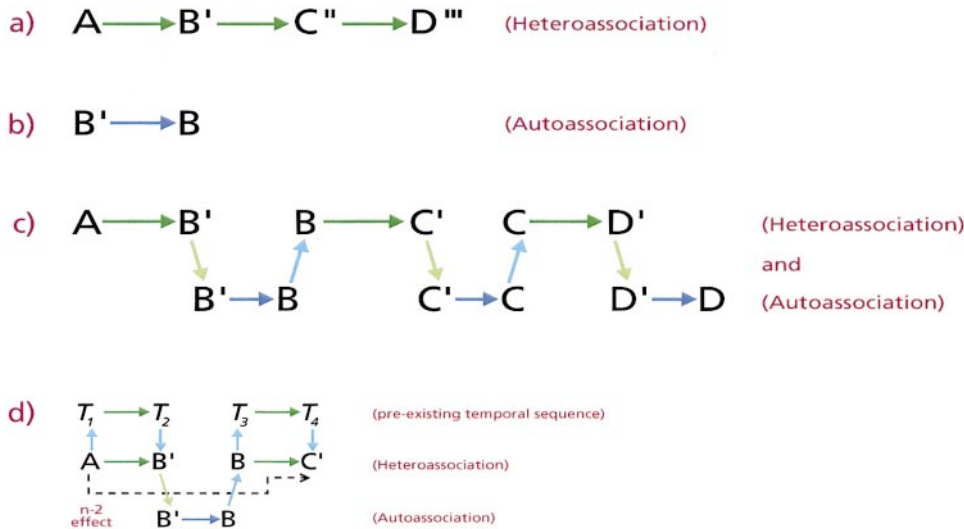

Figure 3. Reciprocally Interacting Heteroassociative and Autoassociative Networks Produce More Accurate Sequence Recall Than a Single Heteroassociative Network

(a) In the simplest heteroassociative network, the cells that encode one memory are selectively connected to the cells that encode the next memory in a sequence. With each successive step in the sequence recall process, the memory becomes more degraded, as indicated by the number of primes. A single network can accurately recall sequences if there is a high degree of correlation between successive memories, but this will not work in the general case.

(b) An autoassociative network that stores the associations that constitute each memory item is capable of producing the correct version of any item (e.g., B) when presented with a degraded version (e.g., B').

(c) Accurate sequence prediction through the reciprocal interactions of two networks. One network is heteroassociative. When the next item in the sequence is produced, it is sent to the autoassociate network, which is able to correct it. This corrected version is then sent back to the heteroassociative network, where it serves as a basis for the next step in the predictive process. Not enough information is available for a detailed simulation of how this could be carried out by CA3 and dentate networks, but the following is an example of how some of the key problems might be dealt with. A cycle begins when memory A cells of CA3 excite memory B cells of CA3 through recurrent connections, causing single spikes in these cells and pattern B'. The spikes are transmitted to the dentate network, where the correct granule cells for the item B are excited (because of direct input from CA3 or indirect input through mossy cells). These "correct" granule cells then fire the "correct" CA3 cells. This causes a burst and initiates the next cycle. If a CA3 cell representing B did not fire because of recurrent input (a false negative), it will fire because of mossy fiber input. A CA3 cell that is a false positive will fire only a single spike (since it will not get mossy fiber input). If only bursts are effectively transmitted to other CA3 cells by the facilitating recurrent synapses (Lisman, 1997), false positives will have little impact.

(d) Complexities of sequence storage and recall. First, psychophysical evidence indicates that sequence memory is not strictly a pairwise process between memories n and n-1. The dashed arrow indicates that connections between memories n-2 and n may also contribute (see Jensen and Lisman, 1996c for how a multiplexing buffer makes this possible). Second, studies of human memory (Howard and Kahana, 1998) and nerve network simulations (Levy, 1996) suggest that sequence items can be autoassociated with a preexisting sequence that can be thought of as a sequence of time steps (t1, t2, etc.). Heteroassociation may therefore not be obligatory for sequence learning.

presentation to be synaptically encoded by an LTP-type process that requires repetitive firing to produce synaptic modification. Of particular relevance to sequence learning is the possibility that such buffers can hold multiple items active at the same time by a multiplexing mechanism (Lisman and Idiart, 1995; Jensen and Lisman, 1996b). According to the multiplexing model, items that are presented sequentially during learning are represented in sequential gamma cycles, as illustrated in Figure 2c, and the entire pattern repeats for many seconds in every theta cycle (see Figure 2c legend for a description of possible physiological mechanisms). A buffer of this kind would allow an LTP-type process (with a delay window of 100 ms) to form asymmetrical memory linkages between sequential memory items in a manner consistent with psychophysical results (Figure 3d), even if the events occurred seconds apart (as in Jerry's story) (Jensen and Lisman, 1996c, 1998). There are thus physiologically plausible mechanisms by which realistic sequences of events could be encoded into long-term memory.

The findings summarized in the preceding paragraphs form the basis of the view that the CA3 region is not an autoassociative network, as previously proposed (autoassociation would symmetrically link Jerry and dropped and candy). Rather, according to second generation models (Blum and Abbott, 1996; Jensen and Lisman, 1996a; Levy, 1996; Tsodyks et al., 1996; Wallenstein and Hasselmo, 1997), CA3 is a heteroassociative network that links different memories that occurred at different times (heteroassociation asymmetrically links "Jerry dropped candy" to "monkey reached through cage and grabbed it"). The next section will develop the idea that the reciprocally connected dentate and CA3 networks provide a solution to the special problems that arise when attempting to accurately recall sequences.

Accurate Sequence Recall by the Reciprocally Connected Recurrent Networks of Dentate and CA3

One observation that at first did not seem to fit with the idea that the phase-advance is generated in CA3 is that

it is also observed in the preceding region, the dentate gyrus (Skaggs and McNaughton, 1996). One possible explanation would be that the information is sent to the dentate from CA3 by the feedback connections (Figure 1). But what would be the purpose of such feedback, and, in the larger sense, what is the purpose of having two reciprocally connected recurrent networks?

Abstract models of sequencing networks suggest an answer to these questions (Kleinfeld, 1986; Sompolinsky and Kanter, 1986). One might at first think that sequencing could be done by a simple heteroassociative recurrent network in which cells encoding memory A were connected to cells encoding memory B, which were then connected to cells encoding memory C, etc. (Figure 3a). However, it can easily be seen that this process will not lead to accurate sequence recall. Because of intrinsic and synaptic noise, memory A cells cannot perfectly activate memory B cells; some memory B cells don't fire (false negatives), while other cells that are not part of memory B do fire (false positives). Memory B is thus somewhat degraded, a degradation signified as B'. The problem gets worse in the next step of sequence recall, when B' is used to activate memory C cells. Because the starting point is inaccurate, the firing of C cells will be even more inaccurate, C''. The result is a concatenation of errors that makes the replay of long sequences problematic. What Sompolinsky and Kleinfeld showed was that this problem could be avoided by a second set of synapses that contained autoassociative information about the specific memory items, i.e., about A, B, and C. A well established capability of autoassociative recurrent networks is to restore a degraded memory to its original form, i.e., convert B' to B (Figure 3b). This corrected memory could then be used to predict C without a concatenation of errors. They proposed that a network could alternately use the autoassociative and heteroassociative synapses to produce accurate sequence recall.

I propose that this principle underlies sequence recall in the hippocampus but that the two sets of synapses are in different recurrent networks; the autoassociative information about memory items may be stored in the dentate, whereas the heteroassociative information that links memory items into a sequence may be stored in CA3. These networks might interact during recall in the following way (Figure 3c): in CA3, memory B cells are fired by recurrent input from memory A cells, but with errors, resulting in pattern B'; this pattern is sent to the dentate, where it is corrected to B and sent back to CA3; there, it triggers the next cycle of sequence recall. In this way, the two reciprocally interconnected recurrent networks could produce accurate sequence recall.

Evaluation/Predictions

Although the influence of CA3 on the dentate has been demonstrated *in vivo* (Penttonen et al., 1997), this interaction has not yet been described in any detail. More data will therefore be required to determine whether the reciprocal interactions can perform the functions required by the model (see preliminary ideas in Figure 3c legend). What can be evaluated from available data is whether the proposed bidirectional interaction is feasible from a timing standpoint. If each step in sequence recall is linked to one gamma cycle (Figure 2), the bidirectional interaction must occur in less than the period

of the oscillation (25 ms). The evidence suggests that this is feasible, since transmission from CA3 to the dentate takes <3 ms (Wu et al., 1998), and transmission back to CA3 takes <5 ms (Yeckel and Berger, 1990).

A key prediction is that the dentate and CA3 recurrent networks perform the different functions of autoassociation and heteroassociation, respectively. As discussed above, what suggests that the CA3 region is heteroassociative is that the time window of synaptic modification is sufficiently long (~100 ms) to produce heteroassociative linkages (given the evidence that different information is active within this time window [Figure 2]). If the dentate network performs autoassociation, then the time window in this network must be shorter, specifically less than the period of a gamma cycle. One way this could occur would be if the NMDAR deactivation time was short (<30 ms) at either of the two synapses in the dentate recurrent network, and it would thus be of great interest to measure these times. At a more functional level, the model predicts that the accuracy of sequence recall should be reduced by interfering with the function of the dentate or by eliminating the feedback projections from CA3 to dentate.

The Perforant Path Input to CA3 May Provide the Context Signal

I now turn to the possible function of the direct input from the entorhinal cortex to CA3 (Figure 1). This input is called the perforant path input, and I argue that it has a key role in allowing memory sequences to be stored in context. Context refers to the general, relatively constant features of the environment. In our example, the zoo is the context. Cotton candy and animal smells are part of what makes up context. The importance of the hippocampus in encoding contextual information has been demonstrated in behavioral experiments. For instance, during aversive conditioning; given a choice of environments, normal animals will move to the environment in which they were not shocked when a conditioned stimulus is given. After hippocampal lesions, animals can still be conditioned, but actions based on context are absent (Selden et al., 1991). The importance of context is also evident in recordings from hippocampal place cells. In a given context, the environment is mapped out by a subset of place cells. In a different context (e.g., room), the environment will be mapped out by a different subset (Muller and Kubie, 1987). About one-third of the cells are potentially active in a given context (Thompson and Best, 1989). This strong context dependence is not observed in the entorhinal cortex (Quirk et al., 1992). Importantly, there are no cells in the hippocampus that fire continuously in a particular context. One explanation is that contextual input to the hippocampus is itself subthreshold. Such a subthreshold depolarization could, however, have important consequences in enabling context-appropriate cells to be triggered by other inputs.

The perforant path input to CA3 could play this enabling role. This pathway terminates in the most distal region of the dendritic tree and is thus the least effective input for firing cells. However, this input could produce a depolarizing bias in target cells that would allow a

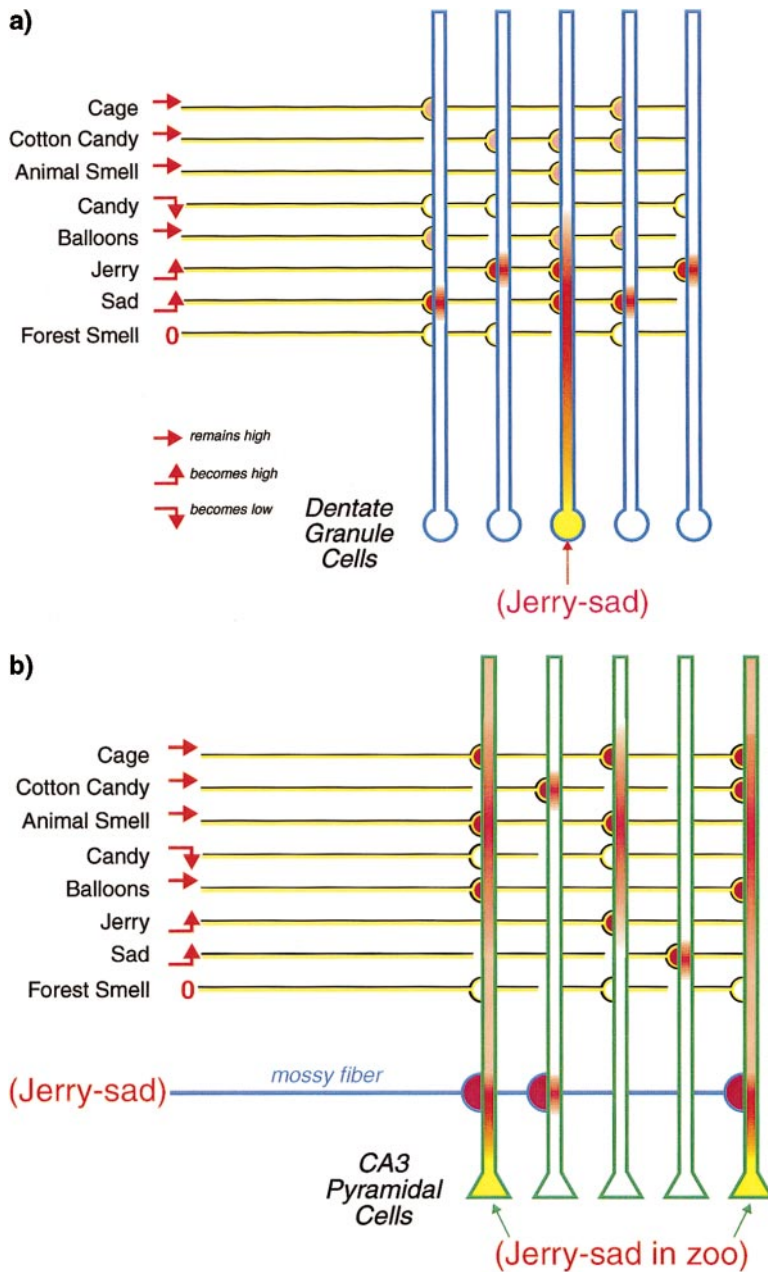

Figure 4. The Role of Dentate Synapses in Filtering Out Context and the Role of the Perforant Path to CA3 in Transmitting Context

(a) At the medial perforant path input to dentate granule cells, contextual information that is steadily firing (horizontal red arrows) is not transmitted because of low-frequency depression. Rapid increases in firing (upward arrows) due to salient information is transmitted. Note that in the dentate, the features Jerry and Sad are represented by the same cell, whereas this is not the case for the cortical input cells. This is what is meant by a change in representation.

(b) The same perforant path axons that provide input to the dentate also provide input to CA3. Even constant "contextual" items produce a subthreshold depolarizing bias in CA3. This bias enables a single powerful mossy fiber input (representing event information) to detonate a CA3 cell. In this way, an item is represented in context, even though context itself does not cause firing (as observed). (For altogether different models for encoding context, see Samsonovich and McNaughton, 1997; Minai and Best, 1998.)

single axonal input from a dentate granule cell to fire the cell. These axons, which are termed mossy fibers, synapse onto CA3 cells at unusually large spines having multiple active zones (Chicurel and Harris, 1992), an observation that led to the proposal that a single mossy fiber might "detonate" (fire) the CA3 cell (McNaughton and Morris, 1987). However, *in vitro* recordings show that the excitatory postsynaptic potential (EPSP) evoked by a single mossy fiber, though large for a unitary EPSP (2–4 mV), is nevertheless too small by itself to detonate the CA3 cell (Brown and Johnston, 1983; Jonas et al., 1993). I suggest that *in vivo*, a subset of CA3 cells is positively biased by a large number of contextually relevant perforant path inputs (that are inactive *in vitro*) and that this bias allows these cells to be detonated by a

single mossy fiber (for details and alternatives, see Figure 4b legend). To use Jerry's story, cells in the entorhinal cortex that represent the properties of zoo would produce a subthreshold depolarization in a subset of CA3 cells. The subset of this subset (Figure 4b) that received mossy fiber input (representing "Jerry dropped candy") would fire and thereby encode "Jerry dropped candy in the zoo" (a different set of cells would fire if he dropped his candy at home). Groups of CA3 cells that encode a given event in a given context have strong recurrent connections with the next event in the sequence, thereby building up the complete episodic memory.

Contextual coding of this kind makes sense, because the hippocampus does not need to repeatedly encode

the relatively constant complex information that describes the zoo context (animal smells, etc.). What does need to be encoded in detail is the changing, salient information (Jerry dropping his candy). But how might contextual information be filtered out by the dentate so that the context does not directly cause firing? One mechanism for such filtration is presynaptic depression, an activity-dependent process that leads to a rapid reduction in transmitter release. This depression is known to be particularly strong at one of the major inputs to the dentate gyrus from the entorhinal cortex, the medial perforant path (McNaughton, 1980). Once this depression develops, steady contextual inputs might become subthreshold for firing granule cells (Figure 4a) and would therefore be irrelevant. In contrast, even if the same depression develops for perforant path inputs to CA3 (Bragin and Otmakhov, 1979), subthreshold signals remain important in CA3, because they make it possible for a single mossy fiber input to fire the cell. We can thus see how steady, contextual information could be filtered out at the dentate and thus not be encoded in detail while retaining the ability to enable a subset of CA3 cells, as required for encoding specific information in context.

Evaluation/Predictions

A prediction of this model is that a single mossy fiber input can fire a CA3 cell provided it is positively biased by context. So much is known about hippocampal firing patterns and about the anatomical connections between the dentate and CA3 that insight into this prediction can be gained by trying to account for the firing pattern in CA3 from that in the dentate. About 0.4% of granule cells and 2.5% of CA3 cells are active when the animal is at a given place (Barnes, 1990). Each CA3 cell receives input from ~50 granule cells (Claiborne et al., 1986). From the binomial distribution, one can calculate that 17% of CA3 cells will receive one or more active mossy fiber inputs, 1.7% will receive two or more, and <0.1% will receive three or more. Assume that of these, only one-third are positively biased by context; the remaining two-thirds are not biased and are therefore silent (Thompson and Best, 1989). Thus, the expected percentage of CA3 cells firing in these three cases is 6%, 0.6%, or <<0.1%. Since the observed value is 2.5%, the possibility that two or more mossy fibers are required to fire a CA3 cell does not appear feasible. From this analysis, it is unlikely that more than one active mossy fiber input is needed to fire a CA3 cell (various sources of failure could lower the probability from 6% to 2.5%). Under some conditions (after removal of the dentate), mossy fiber input may not be at all necessary to fire CA3 cells, since place-specific firing persists (McNaughton et al., 1989). However, it is unclear whether this is a normal operating mode of the hippocampus or is due to compensations resulting from destruction of the dentate. What is known is that during the memory readout (when the phase-advance occurs), the dentate is active and therefore likely to contribute to the firing of CA3 cells (Skaggs and McNaughton, 1996).

More generally, the model points to the importance of the perforant path input to CA3 (and perhaps also to mossy cells) in establishing memory context. This leads to the prediction that interfering with the perforant path

input should abolish the context dependence of hippocampal place cells and the context dependence of episodic memory retrieval. Interfering specifically with this pathway is difficult, and experiments of this kind have not yet been attempted.

The Roles of CA1: Decoder and Match/Mismatch Detector

The CA1 region receives information from CA3 and provides output to the entorhinal cortex. One role of the region is therefore to convey information derived from hippocampal computations back to the cortex. It has been proposed that as part of this process, CA1 acts as a “decoder” (McClelland and Goddard, 1996). The underlying assumption is that the hippocampus and cortex do not use the same representation of information and that CA1 helps to convert the representation back to one that the cortex can understand. The term representation has to do with how cells combine different kinds of information. To use an illustrative example (Figure 4a), there may be cells in the hippocampus that represent the conjunction of Jerry and his feeling of sadness, whereas in the cortex, separate groups of cells encode Jerry and sadness. One purpose of such a change in representation may be to condense representations so that fewer cells encode any given memory. This “orthogonalization” reduces interference between different memories (McNaughton and Morris, 1987; Rolls, 1996; Hasselmo and Wyble, 1997). The evidence is fairly good that a change in representation of incoming information occurs. First, place fields in the hippocampus are smaller than in entorhinal cortex; and second, anatomically distinct subregions of entorhinal cortex, which presumably carry different types of information, converge on individual granule cells (see Johnston and Amaral, 1998).

Another argument for a change in representation can be developed based on whether pathways are “point-to-point” or “fanning.” We know from work in the visual system that a subregion of V1 representing a given part of the visual field makes a point-to-point projection to a subregion in V2 that represents the same part of the field (Covey, 1964). Point-to-point connections are thus indicative of a similar representation of information in the two regions (a retinotopic representation in this case). In contrast, strongly divergent fanning connections are indicative of a major change in representation. Figure 1 illustrates that some hippocampal pathways are fanning (f) while others are point-to-point (p-p) (as summarized in Buzsáki, 1996). The reason for these differences has been completely unclear. Examination of Figure 1, however, reveals that there is a simple explanation for the entire pattern. If it is assumed that a cortical representation is converted to a hippocampal representation in the dentate and that this representation is also used by CA3 but is converted back to a more cortical representation by CA1, then one can see that a simple rule is obeyed: the feedforward connections between regions that use the same representation (dentate to CA3, CA1 to cortex) are all point-to-point, whereas those between regions using different representations are all fanning (cortex to dentate, cortex to CA3, CA3 to CA1).

In addition to its role as a decoder, CA1 may also have a role in making a match/mismatch computation in which sensory "reality" arriving directly from the entorhinal cortex is compared with predictions of reality made by dentate-CA3. This idea has been incorporated into several models (Lynch and Ranger, 1992; Hasselmo and Schnell, 1994; Blum and Abbott, 1996; Levy, 1996). The idea of such a comparison relates to the long standing proposal that the brain forms a model of the world based on past events (Sokolov, 1963). This model, which can be thought of as stored sequences, allows prediction of expected events (if this happens, then I expect that to happen). The brain continuously compares these expectations with reality. If the comparison shows a "mismatch" to expectations or something altogether novel, memory encoding and attentional processes are triggered. Evidence that the human hippocampus is involved in such processes comes from brain imaging (Dolan and Fletcher, 1997) and electrophysiological studies (Halgren et al., 1980; Knight, 1996). Related experiments in rat and rabbit show that hippocampal neurons become habituated to a repetitive stimulus but respond vigorously when the standard stimulus is replaced by an "oddball" stimulus (Buzsáki et al., 1979; Vinogradova, 1984). Other experiments in rat directly show activity related to match/mismatch conditions (Otto and Eichenbaum, 1992). The clearest demonstration of the existence of an internal model comes from experiments in which a repetitive stimulus was suddenly omitted. Cells in the mammillary body, one of the recipients of hippocampal output, fire in exact registration with the expected onset and duration of the absent stimulus (Vinogradova, 1984). Because the CA1 region is the site of convergence of predictions from CA3 (via the Schaffer collaterals) and raw sensory information (via the perforant path input from the cortex) (Vinogradova, 1984), CA1 is well positioned to perform a match/mismatch computation.

Evaluation/Predictions

The strongest direct evidence for a representation change between CA3 and CA1 is anatomical, based on the re-segregation in CA1 of specialized medial and lateral perforant path streams of information that had converged in the dentate and CA3 (Naber and Witter, 1998). What remains lacking is physiological evidence for this change in representation. Indeed, the identical size of place fields in CA3 and CA1 argues to the contrary. Perhaps now that it is clear that the rat hippocampus encodes features other than spatial position (Eichenbaum, 1996), more studies will be done on non-spatial variables, and these may reveal differences between CA1 and CA3 representations.

Although several lines of evidence implicate the hippocampus in the determination of match/mismatch, there has been no cellular analysis of how these computations occur. It is even unclear whether the system computes match (presumably by a coincidence detection process) or mismatch (by a subtractive inhibitory process). The specific prediction of the model presented here is that the computation should be prevented by interrupting either of the two inputs to CA1. Recent work shows that dopamine can strongly inhibit the perforant path input to CA1 without affecting the input from CA3,

and this would be expected to disrupt match/mismatch computations (Otmakhova and Lisman, 1999). Hyperdopaminergic conditions have been implicated in schizophrenia, and it thus intriguing that signals related to match/mismatch detection are aberrant in schizophrenics (Blackwood et al., 1987).

Summary and Conclusions

The view that emerges of the hippocampus is a relatively simple one that can be related to the functional requirements of episodic memory and more specifically to the storage and retrieval of memory sequences in context. The dentate and CA3 store autoassociations and heteroassociations, respectively, in the synapses of their recurrent connections. During retrieval, these networks work together to produce an accurate time-compressed recall of a stored sequence. The role of the perforant path input to CA3 relates to the general problem of how episodic memory sequences are linked to their context. It is proposed that contextual information arriving through the perforant path enables a subset CA3 cells (and perhaps also mossy cells). A subset of this subset can be fired by salient memory information represented by mossy fiber activity. In this way, specific memories can be encoded in context without having to explicitly represent highly redundant and detailed contextual information. From CA3, information travels to CA1, a region that has two functions. First, it converts the hippocampal representation back to a more cortical one, thereby making it possible for the cortex to interpret the hippocampal output. Second, CA1 cells compare the predictions made by CA3 based on stored memory sequences to sensory reality that arrive through the perforant path input to CA1. If a mismatch is detected, attentional and learning processes are initiated. Together, these ideas provide a coherent explanation of the function of each of the pathways shown in Figure 1.

Recent work shows that it has become possible to produce mice having a molecular modification in a specific hippocampal network (Tsien et al., 1996), specifically deletion of NMDA receptors in CA1. The effect of this mutation is to produce strong deficits in spatial learning. Results of this kind are a challenge to interpret, because they can only be understood in terms of models of great breadth that link processes at the molecular, cellular, network, and behavioral levels. The model proposed here is a step in this direction, but falls short in several ways. In particular, it does not assign a specific function to synaptic modification at all of the hippocampal synapses and does not address the question of how information stored in the hippocampus is utilized by other brain networks.

The rapidly developing methods of molecular biology may soon provide new ways of testing network models. One of the main methods used for elucidating the role of brain regions has been to ablate them and to examine the resulting behavioral changes. In testing network models of the kind proposed here, it would be desirable to make more specific lesions, such as eliminating the feedback connections from CA3 to the dentate. Such specific lesions are not generally possible by surgical methods but may be feasible by molecular methods.

Acknowledgments

I thank Larry Abbott, John Fitzpatrick, Michael Hasselmo, and David Redish for comments on the manuscript and Helen Scharfman, Bill Skaggs, Alexei Samsonovich, Haim Sompolinsky, David Kleinfeld, Howard Eichenbaum, and Gyorgy Buzsáki for useful conversations. This work was supported by the National Science Foundation (IBN-9723466), and the author gratefully acknowledges the support of the W. M. Keck Foundation.

References

- Barnes, C.A. (1990). Effects of aging on the dynamics of information processing and synaptic weight changes in the mammalian hippocampus. *Prog. Brain Res.* *86*, 89–104.
- Blackwood, D.H., Whalley, L.J., Christie, J.E., Blackburn, I.M., St. Clair, D.M., and McInnes, A. (1987). Changes in auditory P3 event-related potential in schizophrenia and depression. *Br. J. Psychiatry* *150*, 154–160.
- Blum, K.I., and Abbott, L.F. (1996). A model of spatial map formation in the hippocampus of the rat. *Neural Comput.* *8*, 85–93.
- Bragin, A., Jando, G., Nadasdy, Z., Hetke, J., Wise, K., and Buzsáki, G. (1995). Gamma (40–100 Hz) oscillation in the hippocampus of the behaving rat. *J. Neurosci.* *15*, 47–60.
- Bragin, A.G., and Otmakhov, N.A. (1979). Comparative characteristics of the direct influences of the perforant pathway on neurons in hippocampal fields CA1 and CA3 in vitro. *Neirofiziologija* *11*, 303–310.
- Brown, T.H., and Johnston, D. (1983). Voltage-clamp analysis of mossy fiber synaptic input to hippocampal neurons. *J. Neurophysiol.* *50*, 487–507.
- Buckmaster, P.S., and Schwartzkroin, P.A. (1994). Hippocampal mossy cell function: a speculative view. *Hippocampus* *4*, 393–402.
- Buzsáki, G. (1996). The hippocampo-neocortical dialogue. *Cereb. Cortex* *6*, 81–92.
- Buzsáki, G., and Chrobak, J.J. (1995). Temporal structure in spatially organized neuronal ensembles: a role for interneuronal networks. *Curr. Opin. Neurobiol.* *5*, 504–510.
- Buzsáki, G., Grastyan, E., Tveritskaya, I.N., and Czopf, J. (1979). Hippocampal evoked potentials and EEG changes during classical conditioning in the rat. *Electroencephalogr. Clin. Neurophysiol.* *47*, 64–74.
- Chicurel, M.E., and Harris, K.M. (1992). Three-dimensional analysis of the structure and composition of CA3 branched dendritic spines and their synaptic relationships with mossy fiber boutons in the rat hippocampus. *J. Comp. Neurol.* *325*, 169–182.
- Claiborne, B.J., Amaral, D.G., and Cowan, W.M. (1986). A light and electron microscopic analysis of the mossy fibers of the rat dentate gyrus. *J. Comp. Neurol.* *246*, 435–458.
- Colombo, M., and Gross, C.G. (1994). Responses of inferior temporal cortex and hippocampal neurons during delayed matching to sample in monkeys (*Macaca fascicularis*). *Behav. Neurosci.* *108*, 443–455.
- Cowey, A. (1964). Projection of the retina on to striate and prestriate cortex in the squirrel monkey, *Saimir sciureus*. *J. Neurophysiol.* *27*, 366–393.
- Debanne, D., Guerineau, N.C., Gähwiler, B.H., and Thompson, S.M. (1995). Physiology and pharmacology of unitary synaptic connections between pairs of cells in areas CA3 and CA1 of rat hippocampal slice cultures. *J. Neurophysiol.* *73*, 1282–1294.
- Dolan, R.J., and Fletcher, P.C. (1997). Dissociating prefrontal and hippocampal function in episodic memory encoding. *Nature* *388*, 582–585.
- Dore, F.Y., Thornton, J.A., White, N.M., and Murray, E.A. (1998). Selective hippocampal lesions yield nonspatial memory impairments in rhesus monkeys. *Hippocampus* *8*, 323–329.
- Eichenbaum, H. (1996). Is the rodent hippocampus just for 'place'? *Curr. Opin. Neurobiol.* *6*, 187–195.
- Eichenbaum, H. (1997). How does the brain organize memories? *Science* *277*, 330–332.
- Gustafsson, B., Wigstrom, H., Abraham, W.C., and Huang, Y.Y. (1987). Long-term potentiation in the hippocampus using depolarizing current pulses as the conditioning stimulus to single volley synaptic potentials. *J. Neurosci.* *7*, 774–780.
- Halgren, E., Squires, N.K., Wilson, C.L., Rohrbaugh, J.W., Babb, T.L., and Crandall, P.H. (1980). Endogenous potentials generated in the human hippocampal formation and amygdala by infrequent events. *Science* *210*, 803–805.
- Hampson, R.E., Heyser, C.J., and Deadwyler, S.A. (1993). Hippocampal cell firing correlates of delayed-match-to-sample performance in rat. *Behav. Neurosci.* *107*, 715–739.
- Hasselmo, M.E., and Schnell, E. (1994). Laminar selectivity of the cholinergic suppression of synaptic transmission in rat hippocampal region CA1: computational modeling and brain slice physiology. *J. Neurosci.* *14*, 3898–3914.
- Hasselmo, M.E., and Wyble, B.P. (1997). Free recall and recognition in a network model of the hippocampus: simulating effects of scopolamine on human memory function. *Behav. Brain Res.* *89*, 1–34.
- Hetherington, P.A., Austin, K.B., and Shapiro, M.L. (1994). Ipsilateral associational pathway in the dentate gyrus: an excitatory feedback system that supports N-methyl-D-aspartate-dependent long-term potentiation. *Hippocampus* *4*, 422–438.
- Honey, R.C., Watt, A., and Good, M. (1998). Hippocampal lesions disrupt an associative mismatch process. *J. Neurosci.* *18*, 2226–2230.
- Hopfield, J.J. (1982). Neural networks and physical systems with emergent collective computational abilities. *Proc. Natl. Acad. Sci. USA* *79*, 2554–2558.
- Howard, M.W., and Kahana, M.J. (1998). Contextual variability and serial position effects in free recall. *J. Exp. Psychol. Learn. Mem. Cogn.*, in press.
- Ishizuka, N., Weber, J., and Amaral, D.G. (1990). Organization of intrahippocampal projections originating from CA3 pyramidal cells in the rat. *J. Comp. Neurol.* *295*, 580–623.
- Jackson, M.B., and Scharfman, H.E. (1996). Positive feedback from hilar mossy cells to granule cells in the dentate gyrus revealed by voltage-sensitive dye and microelectrode recording. *J. Neurophysiol.* *76*, 601–616.
- Jarrard, L.E. (1993). On the role of the hippocampus in learning and memory in the rat. *Behav. Neural Biol.* *60*, 9–26.
- Jensen, O., and Lisman, J. (1996a). Hippocampal CA3 region predicts memory sequences: accounting for the phase precession of place cells. *Learn. Mem.* *3*, 279–287.
- Jensen, O., and Lisman, J.E. (1996b). Novel lists of 7+–2 known items can be reliably stored in an oscillatory short-term memory network: interaction with long-term memory. *Learn. Mem.* *3*, 257–263.
- Jensen, O., and Lisman, J.E. (1996c). Theta/Gamma networks with slow NMDA channels learn sequences and encode episodic memory: role of NMDA channels in recall. *Learn. Mem.* *3*, 264–278.
- Jensen, O., and Lisman, J.E. (1998). An oscillatory short-term memory buffer model can account for data on the sternberg task. *J. Neurosci.* *18*, 10688–10699.
- Johnston, D., and Amaral, D.G. (1998). Hippocampus. In *The Synaptic Organization of the Brain*, Fourth Edition, G.M. Shepherd, ed. (New York: Oxford University Press), pp. 417–458.
- Jonas, P., Major, G., and Sakmann, B. (1993). Quantal components of unitary EPSCs at the mossy fibre synapse on CA3 pyramidal cells of rat hippocampus. *J. Physiol. (Lond)* *472*, 615–663.
- Kamondi, A., Acsády, L., Wang, X.J., and Buzsáki, G. (1998). Theta oscillations in somata and dendrites of hippocampal pyramidal cells in vivo: activity-dependent phase-precession of action potentials. *Hippocampus* *8*, 244–261.
- Kleinfeld, D. (1986). Sequential state generation by model neural networks. *Proc. Natl. Acad. Sci. USA* *83*, 9469–9473.
- Knight, R. (1996). Contribution of human hippocampal region to novelty detection. *Nature* *383*, 256–259.
- Kohonen, T. (1978). *Associative Memory* (Berlin: Springer-Verlag).
- Levy, W.B. (1996). A sequence predicting CA3 is a flexible associator

- that learns and uses context to solve hippocampal-like tasks. *Hippocampus* 6, 579–590.
- Lisman, J.E. (1997). Bursts as a unit of neural information: making unreliable synapses reliable. *Trends Neurosci.* 20, 38–43.
- Lisman, J.E., and Idiart, M.A. (1995). Storage of 7 ± 2 short-term memories in oscillatory subcycles. *Science* 267, 1512–1515.
- Lynch, G., and Ranger, R. (1992). Variations in synaptic plasticity and types of memory in cortico-hippocampal networks. *J. Cognitive Neurosci.* 4, 189–199.
- Marr, D. (1971). Simple memory: a theory for archicortex. *Proc. R. Soc. Lond. B Biol. Sci.* 262, 23–81.
- McClelland, J.L., and Goddard, N.H. (1996). Considerations arising from a complementary learning systems perspective on hippocampus and neocortex. *Hippocampus* 6, 654–665.
- McNaughton, B.L., and Morris, R.G. (1987). Hippocampal synaptic enhancement and information. *Trends Neurosci.* 10, 408–415.
- McNaughton, N., and Morris, R.G. (1987). Chlordiazepoxide, an anxiolytic benzodiazepine, impairs place navigation in rats. *Behav. Brain Res.* 24, 39–46.
- McNaughton, B.L., Barnes, C.A., Meltzer, J., and Sutherland, R.J. (1989). Hippocampal granule cells are necessary for normal spatial learning but not for spatially-selective pyramidal cell discharge. *Exp. Brain Res.* 76, 485–496.
- Minai, A.A., and Best, P.J. (1998). Encoding Spatial Context: A Hypothesis on the Function of the Dentate Gyrus-Hilus System. *JCN*, (Anchorage).
- Muller, R. (1996). A quarter of a century of place cells. *Neuron* 17, 813–822.
- Muller, R.U., and Kubie, J.L. (1987). The effects of changes in the environment on the spatial firing of hippocampal complex-spike cells. *J. Neurosci.* 7, 1951–1968.
- Naber, P.A., and Witter, M.P. (1998). Subicular efferents are organized mostly as parallel projections: a double-labeling, retrograde-tracing study in the rat. *J. Comp. Neurol.* 393, 284–297.
- Nadel, L., and Moscovitch, M. (1997). Memory consolidation, retrograde amnesia and the hippocampal complex. *Curr. Opin. Neurobiol.* 7, 217–227.
- O'Keefe, J., and Dostrovsky, J. (1971). The hippocampus as a spatial map. Preliminary evidence from unit activity in the freely-moving rat. *Brain Res.* 34, 171–175.
- O'Keefe, J., and Recce, M.L. (1993). Phase relationship between hippocampal place units and the EEG theta rhythm. *Hippocampus* 3, 317–330.
- Otmakhova, N., and Lisman, J.E. (1999). Dopamine selectively inhibits the direct cortical pathway to the CA1 hippocampal region. *J. Neurosci.*, in press.
- Otto, T., and Eichenbaum, H. (1992). Neuronal activity in the hippocampus during delayed non-match to sample performance in rats: evidence for hippocampal processing in recognition memory. *Hippocampus* 2, 323–334.
- Penttonen, M., Kamondi, A., Sik, A., Acsády, L., and Buzsáki, G. (1997). Feed-forward and feed-back activation of the dentate gyrus in vivo during dentate spikes and sharp wave bursts. *Hippocampus* 7, 437–450.
- Qin, Y.-L., McNaughton, B.L., Skaggs, W.E., and Barnes, C.A. (1997). Memory reprocessing in corticocortical and hippocampocortical neuronal ensembles. *Philos. Trans. R. Soc. Lond. B Biol. Sci.* 352, 1525–1533.
- Quirk, G.J., Muller, R.U., Kubie, J.L., and Ranck, J.B., Jr. (1992). The positional firing properties of medial entorhinal neurons: description and comparison with hippocampal place cells. *J. Neurosci.* 12, 1945–1963.
- Rolls, E.T. (1996). A theory of hippocampal function in memory. *Hippocampus* 6, 601–620.
- Samsonovich, A., and McNaughton, B.L. (1997). Path integration and cognitive mapping in a continuous attractor neural network model. *J. Neurosci.* 17, 5900–5920.
- Scharfman, H.E. (1991). Dentate hilar cells with dendrites in the molecular layer have lower thresholds for synaptic activation by perforant path than granule cells. *J. Neurosci.* 11, 1660–1673.
- Scharfman, H.E., Kunkel, D.D., and Schwartzkroin, P.A. (1990). Synaptic connections of dentate granule cells and hilar neurons: results of paired intracellular recordings and intracellular horseradish peroxidase injections. *Neuroscience* 37, 693–707.
- Selden, N.R., Everitt, B.J., Jarrard, L.E., and Robbins, T.W. (1991). Complementary roles for the amygdala and hippocampus in aversive conditioning to explicit and contextual cues. *Neuroscience* 42, 335–350.
- Skaggs, W.E., and McNaughton, B.L. (1996). Replay of neuronal firing sequences in rat hippocampus during sleep following spatial experience. *Science* 271, 1870–1873.
- Skaggs, W.E., McNaughton, B.L., Wilson, M.A., and Barnes, C.A. (1996). Theta phase precession in hippocampal neuronal populations and the compression of temporal sequences. *Hippocampus* 6, 149–172.
- Sokolov, E.N. (1963). Higher nervous functions: the orienting reflex. *Annu. Rev. Physiol.* 25, 545–580.
- Sompolinsky, H., and Kanter, I. (1986). Temporal association in asymmetric neural networks. *Phys. Rev. Lett.* 57, 2861–2864.
- Squire, L.R., and Zola, S.M. (1998). Episodic memory, semantic memory, and amnesia. *Hippocampus* 8, 205–211.
- Thompson, L.T., and Best, P.J. (1989). Place cells and silent cells in the hippocampus of freely-behaving rats. *J. Neurosci.* 9, 2382–2390.
- Treves, A., and Rolls, E.T. (1992). Computational constraints suggest the need for two distinct input systems to the hippocampal CA3 network. *Hippocampus* 2, 189–199.
- Tsien, J.Z., Chen, D.F., Gerber, D., Tom, C., Mercer, E.H., Anderson, D.J., Mayford, M., Kandel, E.R., and Tonegawa, S. (1996). Subregion- and cell type-restricted gene knockout in mouse brain. *Cell* 87, 1317–1326.
- Tsodyks, M.V., Skaggs, W.E., Sejnowski, T.J., and McNaughton, B.L. (1996). Population dynamics and theta rhythm phase precession of hippocampal place cell firing: a spiking neuron model. *Hippocampus* 6, 271–280.
- Tulving, E., and Markowitsch, H.J. (1998). Episodic and declarative memory: role of the hippocampus. *Hippocampus* 8, 198–204.
- Vinogradova, O.S. (1984). Functional organization of the limbic system in the process of registration of information: facts and hypotheses. In *The Hippocampus*, R.L. Isaacson and K.H. Pribram, eds. (New York: Plenum Press), pp. 1–69.
- Wallenstein, G.V., and Hasselmo, M.E. (1997). GABAergic modulation of hippocampal population activity: sequence learning, place field development, and the phase precession effect. *J. Neurophysiol.* 78, 393–408.
- Wallenstein, G.V., Eichenbaum, H., and Hasselmo, M.E. (1998). The hippocampus as an associator of discontinuous events. *Trends Neurosci.* 21, 317–323.
- Wolfer, D.P., and Lipp, H.P. (1995). Evidence for physiological growth of hippocampal mossy fiber collaterals in the guinea pig during puberty and adulthood. *Hippocampus* 5, 329–340.
- Wu, K., Canning, K.J., and Leung, L.S. (1998). Functional interconnections between CA3 and the dentate gyrus revealed by current source density analysis. *Hippocampus* 8, 217–230.
- Yeckel, M.F., and Berger, T.W. (1990). Feedforward excitation of the hippocampus by afferents from the entorhinal cortex: redefinition of the role of the trisynaptic pathway. *Proc. Natl. Acad. Sci. USA* 87, 5832–5836.